

DESIGN FEATURES

- Built-in ISO 5211 Mounting Pad Easy Automation
- **Fire Safe** Design Approved
- Ex Anti-static Devices for Ball-Stem-Body
- Blow-out Proof Stem
- Pressure Balance Hole in Ball Slot
- **TA-LUFT** **ISO15848-1** Design Approved
- NACE standard MR0175 & MR0103 (Optional)
- Casting Approved by TÜV AD 2000-Merkblatt W0

APPLICABLE STANDARDS

- Design Standard : ASME B16.34
- Fire Safe : API 607 5th 2005, ISO10497
- Face To Face : ASME B16.10
- Wall Thickness :ASME B16.34
- Flanged End : ASME B16.5 Class 150/300
- Inspection & Testing : API 598



CV / KV VALUES

NPS	CV		KV	
	Class 150	Class 300	Class 150	Class 300
1/2	30	30	26	26
3/4	55	55	48	48
1	96	96	83	83
1 1/4	170	170	147	147
1 1/2	270	270	234	234
2	470	470	407	407
2 1/2	780	780	675	675
3	1150	1150	995	995
4	2100	2100	1817	1817

WEIGHT

NPS	KV-041/KV-061		KV-042/KV-062	
	Weight (kg)	Weight (lb)	Weight (kg)	Weight (lb)
1/2	1.64	3.62	2.45	5.40
3/4	2.03	4.48	3.41	7.52
1	2.87	6.33	4.6	10.2
1 1/4	3.67	8.09	5.6	12.4
1 1/2	5.93	13.1	8.5	18.7
2	8.46	18.7	11.1	24.5
2 1/2	14.3	31.5	16.7	36.8
3	18.8	41.5	26.1	57.5
4	30.2	66.6	42.4	93.5

ASME B 16.5 Class150/300
2-PC Body, Full Port, Flanged Ends Ball Valve

TORQUE VALUES

Close to Open Torque at Various Differential Pressure (ΔP), Standard Seats (TFM1600&PTFE)

unit : in-lb / N-m

Size/ ΔP	75 psig		150 psig		300 psig		700 psig	
	5 bar		10 bar		20 bar		50 bar	
NPS	N-m	In-lb	N-m	In-lb	N-m	In-lb	N-m	In-lb
1/2	5	44	5	44	5	44	5	44
3/4	6	53	6	53	6	53	6	53
1	10	88	10	88	11	97	11	97
1 1/4	13	115	13	115	15	133	17	150
1 1/2	19	168	19	168	22	195	24	212
2	25	221	29	257	32	283	35	310
2 1/2	40	354	45	398	49	434	54	478
3	65	575	72	637	81	717	90	796
4	100	885	110	973	122	1080	135	1195

- Remark : 1.Torques will increase about 30% if seat materials are Reinforced Fiber-Glass PTFE, Carbon-filled. PTFE or EK+PTFE or TFM4215.
2.The torque figures at 5 bar pressure are maximum values to be tested after the valves are placed for 24 hours.
3.For actuator sizing, a safety factor of minimum 30% is recommended.

TECHNICAL INFORMATION

PRESSURE - TEMPERATURE DATA

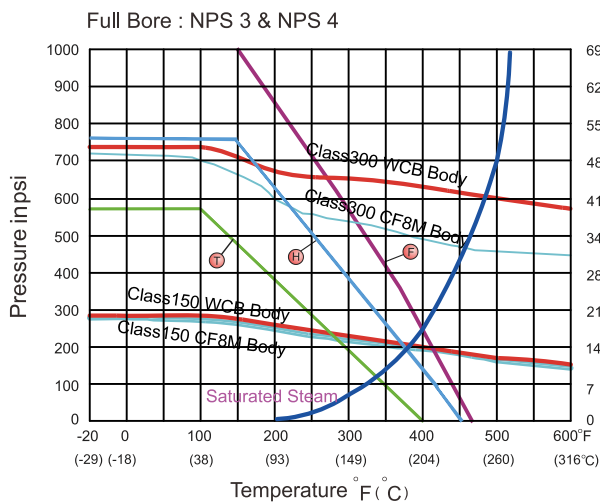
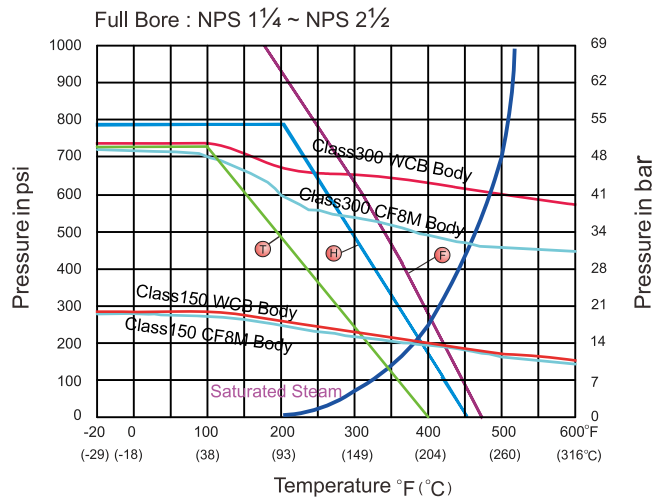
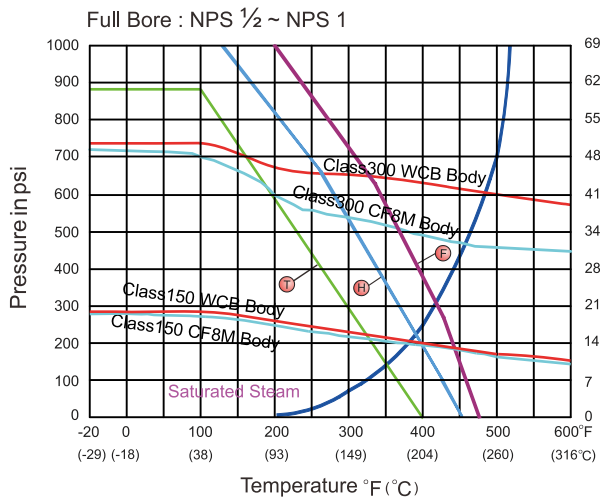

Seat Materials : (T) PTFE (H) TFM1600 (E) TFM4215

The pressure-temperature data of ball valves are determined, not only by valve shell materials but also by sealing materials used for ball seats, gland packings and flange gaskets.

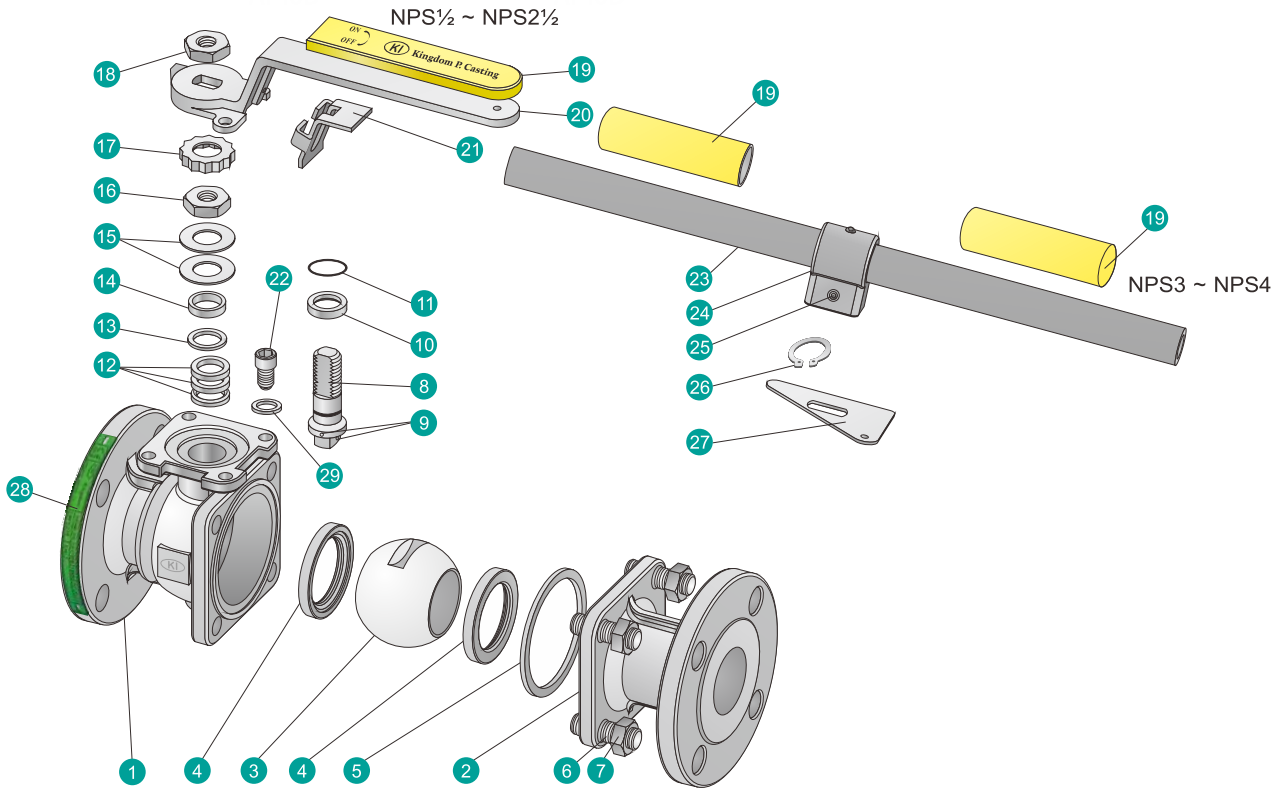

MATERIAL OF CONSTRUCTION

NO.	PART NAME	MATERIALS		
		ANSI	ANSI	ANSI
1	Body	A351-CF8M	A351-CF8	A216-WCB
2	End Cap	A351-CF8M	A351-CF8	A216-WCB
3	Ball	316		304
4	Ball Seat	TFM1600 / PTFE /TFM4215		
5	Body Gasket	PTFE / 316 Spiral Wound+GRAPHITE*		
6	Bolting	A194-B8		A193-B7
7	Bolt Nut	A194-8		A194-2H
8	Stem	316		304
9	Anti-Static	316		304
10	Thrust Washer	PTFE/TFM1600		
11	O-Ring	FKM		
12	Packing	PTFE / GRAPHITE*		
13	Bushing	50%SS+50%PTFE / 304*		
14	Gland	316		
15	Belleville Washer	301		
16	Stem Nut	A194-8		
17	Stop-lock-Cap	304		
18	Handle Nut (NPS1/2~NPS2 1/2)	A194-8		
19	Handle Sleeve	PVC		
20	Handle (NPS1/2~NPS2 1/2)	CF8		
21	Lock Device (NPS1/2~NPS2 1/2)	304		
22	Stop Bolt	A2-70		
23	Pipe Handle (NPS3~NPS4)	A53+PLATED Zn		
24	Handle Adapter (NPS3~NPS4)	A351-CF8		
25	Set Screw (NPS3~NPS4)	A2-70		
26	Snap Screw (NPS3~NPS4)	304		
27	Triangle Stopper (NPS3~NPS4)	304		
28	Nameplate	304		
29	Stop Washer	304		

*Materials for KV-061, KV-062 Series (Fire Safe Models)

ASME B 16.5 Class150/300
2-PC Body, Full Port, Flanged Ends Ball Valve

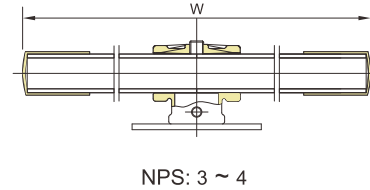
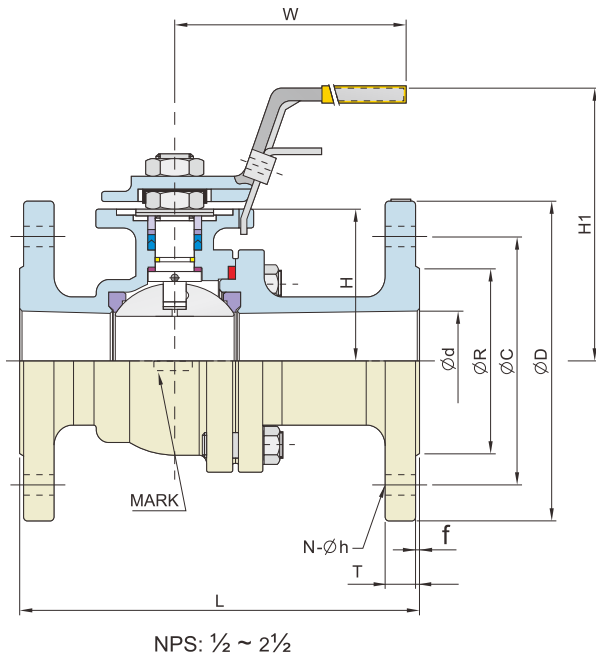
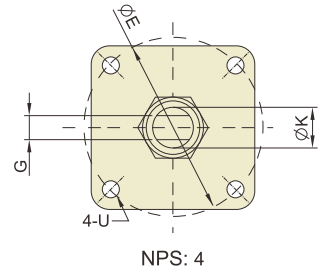
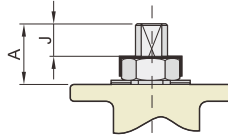
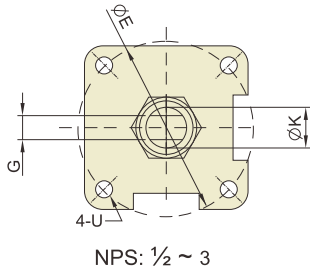

DIMENSION TABLE

■ ASME Class 150

KV-041, KV-061

Unit : mm

NPS	d	L	R	D	C	f	T	H	H1	N	h	W	G	A	J	K	U	E	ISO 5211
1/2	15.0	108	35.0	89	60.5	1.5	7.9	37.0	87	4	16	137	6.3	20	10	12	M5	42	F04
3/4	20.0	117	43.0	99	69.8	1.5	8.6	40.0	90	4	16	137	6.3	20	10	12	M5	42	F04
1	25.0	127	51.0	108	79.2	1.5	9.7	46.0	98	4	16	172	9.0	24	11	15	M6	50	F05
1 1/4	32.0	140	63.5	117	88.9	1.5	11.2	50.0	102	4	16	172	9.0	24	11	15	M6	50	F05
1 1/2	38.0	165	73.2	127	98.6	1.5	12.7	62.0	114	4	16	202	9.6	27	16	16	M8	70	F07
2	50.0	178	92.0	152	120.6	1.5	14.2	71.0	127	4	19	202	9.6	27	16	16	M8	70	F07
2 1/2	64.0	190	105.0	178	139.7	1.5	15.7	89.0	154	4	19	252	16.0	43	21	24	M10	102	F10
3	76.0	203	127.0	190	152.4	1.5	17.5	100.0	185	4	19	304	16.0	43	21	24	M10	102	F10
4	100.0	229	157.2	229	190.5	1.5	22.4	120.5	216	8	19	404	18.0	50	25	29	M10	102	F10

■ ASME Class 150

KV-041, KV-061

Unit : inch

NPS	d	L	R	D	C	T	f	N	h	H	H1	W	G	A	J	E	U	ISO 5211
1/2	0.59	4.25	1.38	3.50	2.38	0.31	0.06	4	5/8	1.46	3.43	5.39	0.248	0.79	0.39	1.65	M5	F04
3/4	0.79	4.62	1.69	3.88	2.75	0.34	0.06	4	5/8	1.57	3.54	5.39	0.248	0.79	0.39	1.65	M5	F04
1	0.98	5.00	2.01	4.25	3.12	0.38	0.06	4	5/8	1.81	3.86	6.77	0.354	0.94	0.43	1.97	M6	F05
1 1/4	1.26	5.50	2.50	4.62	3.50	0.44	0.06	4	5/8	1.97	4.02	6.77	0.354	0.94	0.43	1.97	M6	F05
1 1/2	1.50	6.50	2.88	5.00	3.88	0.50	0.06	4	5/8	2.44	4.49	7.95	0.378	1.06	0.63	2.76	M8	F07
2	1.97	7.00	3.62	6.00	4.75	0.56	0.06	4	3/4	2.80	5.00	7.95	0.378	1.06	0.63	2.76	M8	F07
2 1/2	2.50	7.50	4.12	7.00	5.50	0.62	0.06	4	3/4	3.50	6.06	9.92	0.630	1.69	0.83	4.02	M10	F10
3	2.99	8.00	5.00	7.50	6.00	0.69	0.06	4	3/4	3.94	7.36	11.9	0.630	1.69	0.83	4.02	M10	F10
4	3.94	9.00	6.19	9.00	7.50	0.88	0.06	8	3/4	4.76	8.50	15.9	0.709	1.97	0.98	4.02	M10	F10

ASME B 16.5 Class150/300
2-PC Body, Full Port, Flanged Ends Ball Valve

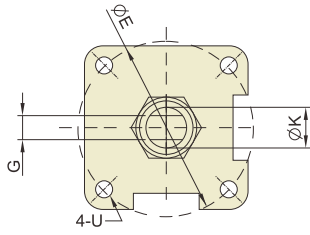

NPS: 1/2 ~ 3

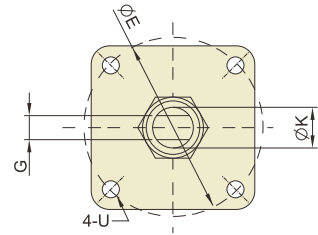
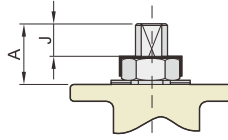

NPS: 4

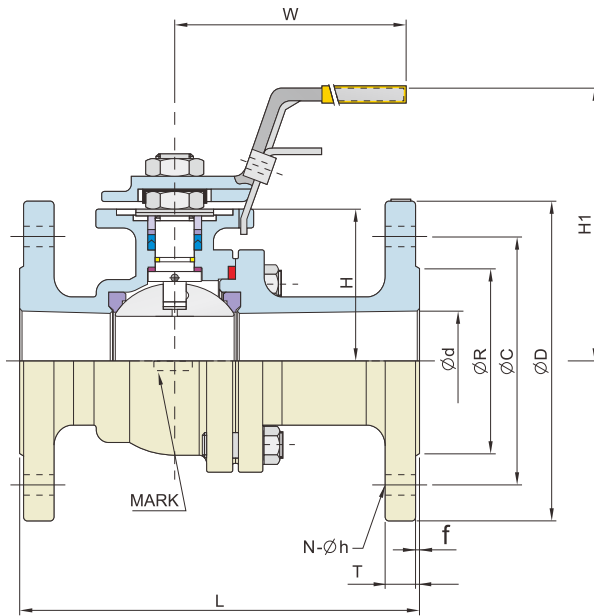

NPS: 1/2 ~ 2 1/2

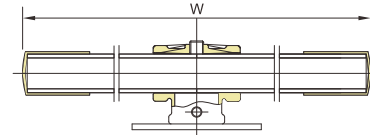

NPS: 3 ~ 4

DIMENSION TABLE

■ ASME Class 300

KV-042, KV-062

Unit: mm

NPS	d	L	R	D	C	f	T	H	H1	N	h	W	G	A	J	K	U	E	ISO 5211
1/2	15.0	140	35.0	95	66.5	1.5	12.7	37	87	4	16.0	137	6.3	20	10	12	M5	42	F04
3/4	20.0	152	43.0	117	82.6	1.5	14.2	40	90	4	19.0	137	6.3	20	10	12	M5	42	F04
1	25.0	165	51.0	124	88.9	1.5	15.7	46	98	4	19.0	172	9.0	24	11	15	M6	50	F05
1 1/4	32.0	178	63.5	133	98.6	1.5	17.5	50	102	4	19.0	172	9.0	24	11	15	M6	50	F05
1 1/2	38.0	190	73.2	155	114.3	1.5	19.0	62	114	4	22.3	202	9.6	27	16	16	M8	70	F07
2	50.0	216	92.0	165	127.0	1.5	20.6	71	127	8	19.0	202	9.6	27	16	16	M8	70	F07
2 1/2	64.0	241	104.7	190	149.4	1.5	23.9	89	154	8	22.3	252	16.0	43	21	24	M10	102	F10
3	76.0	282	127.0	210	168.1	1.5	26.9	100	185	8	22.3	304	16.0	43	21	24	M10	102	F10
4	100.0	305	157.0	254	200.2	1.5	30.2	121	216	8	22.3	404	18.0	50	25	29	M10	102	F10

■ ASME Class 300

KV-042, KV-062

Unit: inch

NPS	d	L	R	D	C	T	f	N	h	H	H1	W	G	A	J	E	U	ISO 5211
1/2	0.59	5.50	1.38	3.75	2.62	0.50	0.06	4	5/8	1.46	3.43	5.39	0.248	0.79	0.39	1.65	M5	F04
3/4	0.79	6.00	1.69	4.62	3.25	0.56	0.06	4	3/4	1.57	3.54	5.39	0.248	0.79	0.39	1.65	M5	F04
1	0.98	6.50	2.01	4.88	3.50	0.62	0.06	4	3/4	1.81	3.86	6.77	0.354	0.94	0.43	1.97	M6	F05
1 1/4	1.26	7.00	2.50	5.25	3.88	0.69	0.06	4	3/4	1.97	4.02	6.77	0.354	0.94	0.43	1.97	M6	F05
1 1/2	1.50	7.50	2.88	6.12	4.50	0.75	0.06	4	7/8	2.44	4.49	7.95	0.378	1.06	0.63	2.76	M8	F07
2	1.97	8.50	3.62	6.50	5.00	0.81	0.06	8	3/4	2.80	5.00	7.95	0.378	1.06	0.63	2.76	M8	F07
2 1/2	2.50	9.50	4.12	7.50	5.88	0.94	0.06	8	7/8	3.50	6.06	9.92	0.630	1.69	0.83	4.02	M10	F10
3	2.99	11.12	5.00	8.25	6.62	1.06	0.06	8	7/8	3.94	7.36	11.9	0.630	1.69	0.83	4.02	M10	F10
4	3.94	12.00	6.19	10.00	7.88	1.19	0.06	8	7/8	4.76	8.50	15.9	0.709	1.97	0.98	4.02	M10	F10